

Technische fiche :

# 150 AETJ-C



 **MANITOU**  
HANDLING YOUR WORLD

Capacities		Metrisch
Working height	h21	15 m
Platform height	h7	13 m
Max. outreach		7.60 m
Overhang		7 m
Pendular arm rotation (top / bottom)		+65 ° / -65 °
Platform capacity	Q	200 kg
Turret rotation		355 °
Platform rotation (right / left)		66 ° / 59 °
Number of people (inside / outside)		2 / 2
Weight and dimensions		
Platform weight*		6700 kg
Platform dimensions (length x width)	lp / ep	0.92 m x 1.20 m
Overall width	b1	1.50 m
Overall length	l1	6.05 m
Overall height	h17	1.97 m
Overall length (stowed)	l9	4.40 m
Overall height (stowed)	h18	2.08 m
Floor height (access)	h20	0.40 m
Jib length	l13	1.26 m
Counterweight offset (turret at 90°)	a7	0.12 m
Internal turning radius (over tyres)	b13	1.87 m
External turning radius	Wa3	3.96 m
Tailswing		0.12 m
Ground clearance at centre of wheelbase	m2	0.14 m
Wheelbase	y	2 m
Performances		
Drive speed - stowed		5 km/h
Drive speed - raised		0.60 km/h
Gradeability		22 %
Permissible leveling		3 °
Wheels		
Tyres type		Solid non-marking tires
Drive wheels (front / rear)		0 / 2
Steering wheels (front / rear)		2 / 0
Braking wheels (front / rear)		0 / 2
Engine/Battery		
Electric engine power rating		2 x 4.50 kW
Electric Pump		3.70 kW
Battery / Batteries capacity		48 V / 240 Ah
Integrated charger (V / A)		48 V / 30 A
Miscellaneous		
Number of cycles with STD Battery (HIRD)		46
Ground Pressure		13.50 dan/cm <sup>2</sup>
Hydraulic Pressure		210 bar
Hydraulic tank capacity		15 l
Vibration on hands/arms		< 2.50 m/s <sup>2</sup>
Standards compliance		
This machine is in compliance with:		European directives: 2006/42/EC- Machinery (revised EN280:2013) - 2004/108/EC (EMC) - 2006/95/EC (Low voltage)

# 150 AETJ-C - Lastendiagram

Load Chart metric

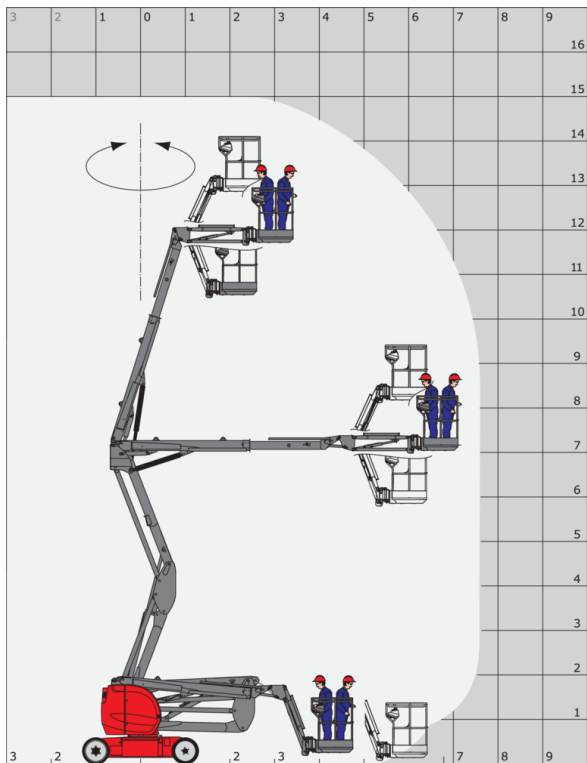

# 150 AETJ-C - Tekening met afmetingen

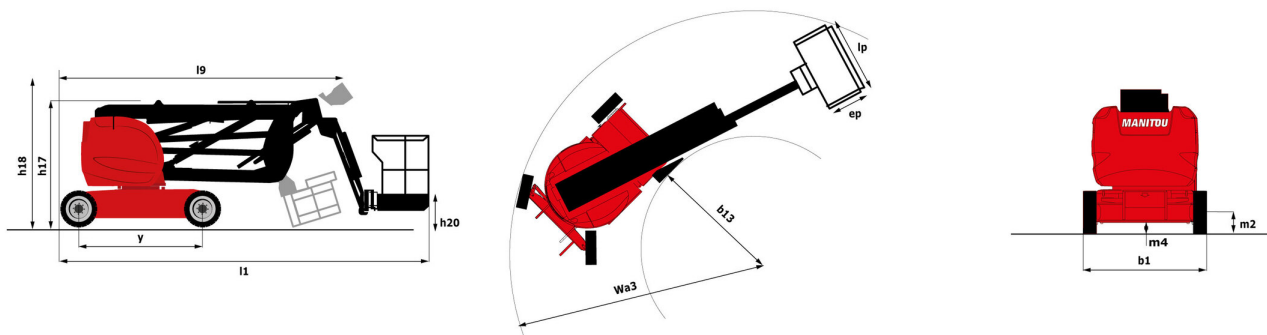

# Uitrusting

---

## Standaard

230V Predisposition  
Audible alarm and illuminated indicator lamp (leveling, overload, lowering)  
Battery charge indicator lamp  
CAN bus technology  
Easy Manager  
Emergency stop button in platform and on frame  
Hom in the platform  
Hour meter  
Integrated diagnostic assistance  
Manual emergency lowering  
Multi-voltage integrated charger  
Negative-type braking on rear wheels  
Non-marking rubber tyres  
Pendular arm  
Platform with open-work floor  
Proportional controls  
Slings and securing rings  
Tool box in platform  
Traction battery  
Travel possible at maximum height

## Optioneel

110 or 230V plug with differential circuit breaker  
3D  
Beep on every movement  
Beep upon travel  
Biodegradable oil  
Centralized recharging of battery  
Cold weather protection oil  
Highly capacity battery  
Lights  
Maintenance-free battery  
Personalized paintwork  
Protective cover for control panel  
SMS : Safe Man System  
Safety harness  
Water predisposition  
Working headlight in platform



Siège Social  
430 rue de l'Aubinière - 44150 Ancenis Cedex - France  
Tel: +33(0)2 40 09 10 11 - Fax: +33 (0)2 40 09 10 97  
[www.manitou.com](http://www.manitou.com)



Deze publicatie geeft een beschrijving van de versies en configuratiemogelijkheden van de Manitou-producten, waarvan de uitrusting kan verschillen. De afgebeelde uitrustingen in deze brochure kunnen standaard, optioneel of niet leverbaar zijn, afhankelijk van de versies. Manitou behoudt zich het recht voor om op te allen tijde en zonder voorafgaande kennisgeving de vermelde specificaties te wijzigen. De weergegeven specificaties zijn niet bindend voor de fabrikant. Voor meer bijzonderheden kunt u uw Manitou dealer raadplegen. Dit document is niet contractueel. De presentatie van de producten is niet contractueel. Specificatielijst is niet uitputtend. De logo's, evenals de visuele identiteit van de onderneming zijn eigendom van Manitou en mogen niet zonder toestemming worden gebruikt. Alle rechten voorbehouden. De foto's en schema's in deze brochure zijn bedoeld als informatie en zijn indicatief.

MANITOU BF NV - Naamloze vennootschap met raad van bestuur - Kapitaal: 39 668 399 euro - 857 802 508 RCS Nantes